

MDB FILTER STACK ISOMETRIC VIEW 1

ONE REQUIRED AS SHOWN
ONE REQUIRED OPPOSITE HAND

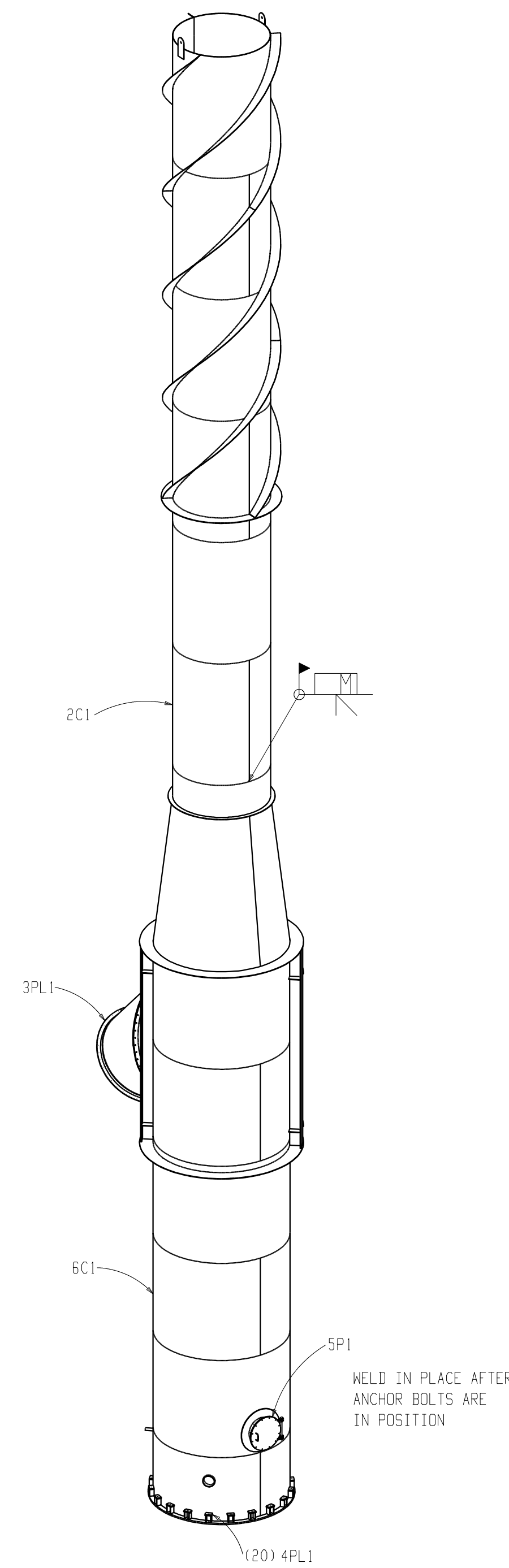
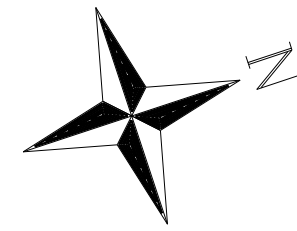

MDB FILTER STACK ISOMETRIC VIEW 2

ONE REQUIRED AS SHOWN
ONE REQUIRED OPPOSITE HAND

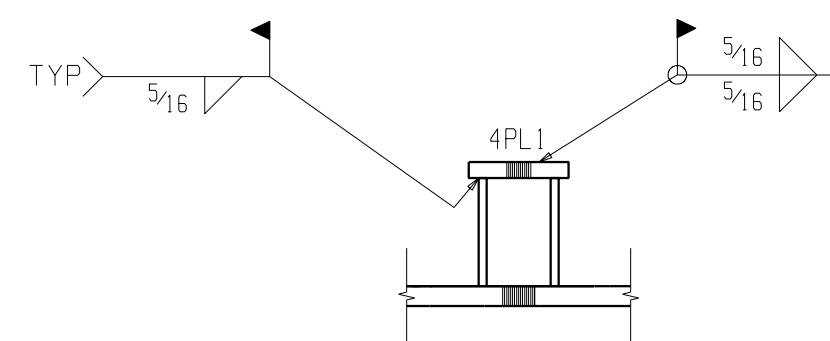
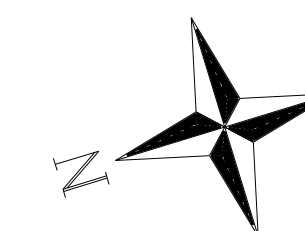

DETAIL 1

NOTE(S):
1) E.O.R. TO VERIFY ALL NEW AND EXISTING MEMBERS.

TAG NO:
08-MB-HVAC-STK0801
(WEST FILTER STACK)

TAG NO:
08-MB-HVAC-STK0802
(EAST FILTER STACK)

MATERIAL THICKNESS OF THICKER PART JOINTED (IN.)	MINIMUM SIZE OF FILLET WELD (IN.) (U.N.O.)	REV#	DESCRIPTION	BY	DATE
UP TO 5/16	1/4 E70XX	A	FOR REVIEW	PK	06-05-12
3/8 TO 3/4	1/4 E70XX	0	FOR FABRICATION	PK	07-03-12
OVER 3/4	5/16 E70XX				

CLIENT:	TITLE: MDB FILTER STACK ISO
PROJECT: BGCAPP FABRICATED STACKS	LOCATION: RICHMOND, KENTUCKY
DETAILING COMPANY: VP & ASSOCIATES, INC.	ENGINEER: -
P.O.: 24915-000-POA-MBSS-00001	REF. DWG.: -
JOB NO.: 12-63106	DWG NO.: E1 REV.: 0