

Section B-B  
1111C1

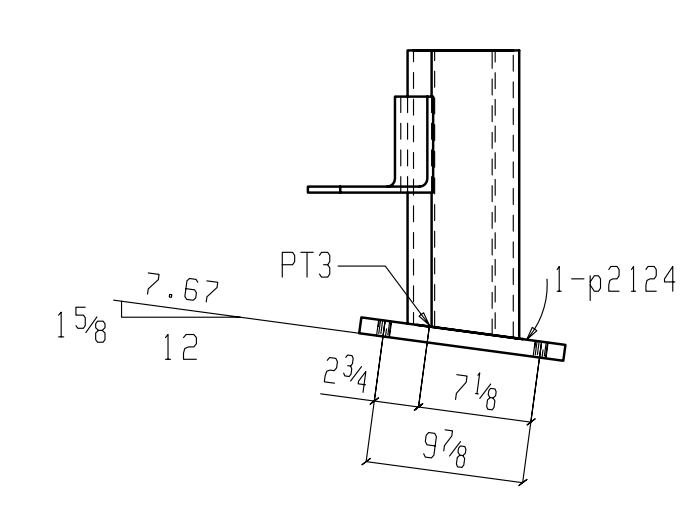

Section C-C  
1111C1

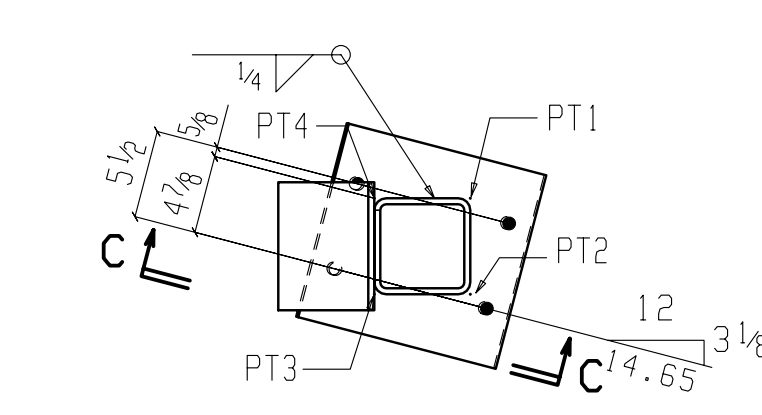

Section A-A  
1111C1

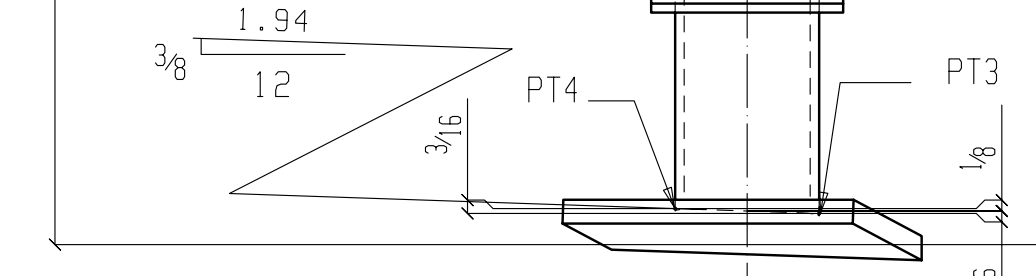

DETAIL#1  
1111C1

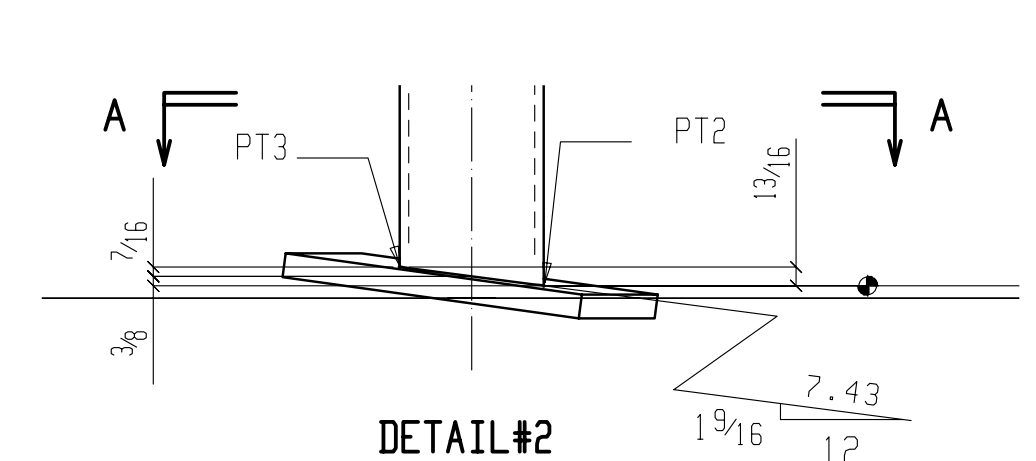

DETAIL#2  
1111C1

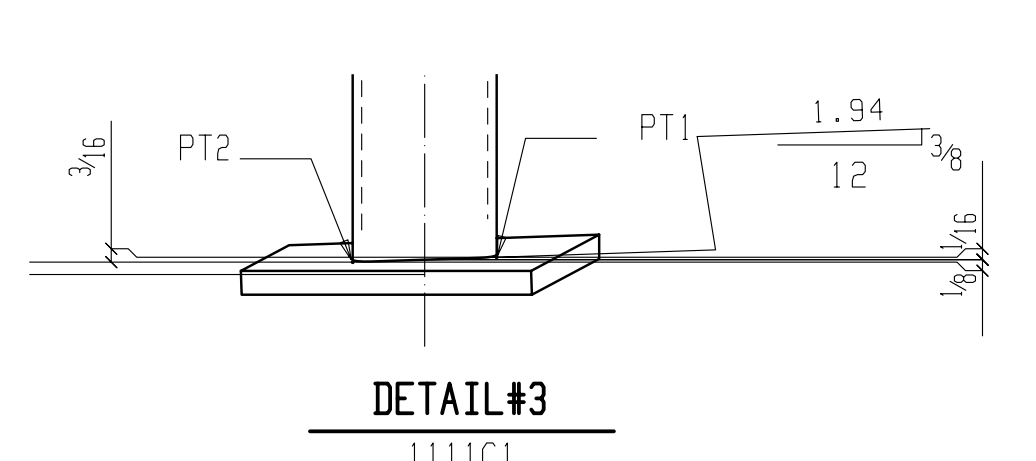

DETAIL#3  
1111C1

ONE COLUMN 1111C1-G  
1521-26  
SEAL WELDS FOR GALV

BILL OF MATERIAL

PC MARK	MINDR MARK	QTY. TOTAL	DESCRIPTION	LENGTH		STEEL GRADE	REMARKS	WEIGHT	
				FEET	INCHES			EA.	TOTAL
1111C1		ONE	COLUMN				Galv	329	329
	1111C1	1	HSS6x6x3/8	8	3/2	A500B	BIE SIE 16-29	228	227
	a139	4	1/2x6x3/8	0	8	A36		10	40
	p2124	1	PL1x12 1/2	1	0 7/8	A36		46	46
	bp16_1	1	PL 3/8x6	0	6	A36		4	4
	f309	3	FL 3/8x4 1/2	0	8 1/2	A36		5	12
			FIELD BOLTS						
		4	TC 3/4 Dia A325SC	0	3		+1HD WASH GALV		

QTY.	PRINTS FOR	DATE	DESCRIPTION	HOLES U.N.	SHOP BOLTS U.N.	FIELD BOLTS U.N.	WELDS U.N.
				13/16	3/4 A325N	3/4 A325N	E70XX LO HYD
							DATE: 08-01-15
							DRAWN BY: TL
2		01-12-16	ADDED DETAILS				CHKD BY: VP
1		12-21-15	RELEASE FOR FABRICATION				JOB NO.: 1521
0		08-24-15	FOR APPROVAL				SHT. NO.: 1111
REV.		DATE	DESCRIPTION	ARCH.: Hellmuth,Obata,& Kassabaum, INC.	ENG.: Walter P Moore & Associates, Inc	CUSTOMER: SKANSKA USA BUILDING	PROJECT MGR:

